

A-52-01

MIL-A-48611A
 30 March 1981
 SUPERSEDING
 MIL-A-48611(MU)
 6 April 1977

MILITARY SPECIFICATION

ADHESIVE SYSTEM, EPOXY-ELASTOMERIC, FOR GLASS TO METAL

This specification is approved for use by all Departments and Agencies of the Department of Defense.

1. SCOPE

1.1 Scope. This specification covers elastomer modified epoxy resin adhesive bonding systems for the structural joining of optical glass prisms to metal, the sealing of glass and metal components, and for other applications requiring bonding of a similar nature.

1.2 Classification. The adhesive bonding systems shall be of the following types, as specified (see 6.2).

Type I - System composed of an epoxy primer component and an epoxy adhesive component.

Type II - System composed of an epoxy adhesive component.

2. APPLICABLE DOCUMENTS

2.1 The following documents, of the issue in effect on date of invitation for bids or request for proposal, form a part of the specification to the extent specified herein.

SPECIFICATIONS

FEDERAL

QQ-A-250/4	Aluminum Alloy 2024, Plate and Sheet
QQ-A-250/12	Aluminum Alloy 7075, Plate and Sheet
PPP-B-636	Box, Shipping, Fiberboard
PPP-T-76	Tape, Packaging, Paper (For Carton Sealing)

Beneficial comments (recommendations, additions, deletions), and any pertinent data which may be of use in improving this document, should be addressed to: Commander, US Army Armament Research and Development Command, ATTN: DRDAR-TST-S, Dover, New Jersey 07801, by using the self-addressed Standardization Document Improvement Proposal (DD Form 1426), appearing at the end of this document, or by letter.

FSC 8040 M

MIL-A-48611A

STANDARDS

FEDERAL

FED-STD-141

Paint, Varnish, Lacquer and Related
Materials; Method of Inspection,
Sampling and Testing

MILITARY

MIL-STD-105

Sampling Procedure and Tables for
Inspection by Attributes

MIL-STD-129

Marking for Shipment and Storage

MIL-STD-810

Environmental Test Methods

(Copies of specifications and standards required by suppliers in connection with specific procurement functions should be obtained from the procuring activity or as directed by the contracting officer.)

3. REQUIREMENTS

3.1 Qualification. The adhesive system furnished under this specification shall be a product which is qualified for listing on the applicable qualified products list at the time set for opening of bids (see 4.5 and 6.3).

3.2 Materials.

3.2.1 Components. The components of the Type I adhesive system shall consist of a primer and an epoxy-elastomer adhesive. The components of the Type II adhesive system shall consist of the epoxy-elastomer adhesive only.

3.2.2 Adhesive. The adhesive shall be a thermosetting resin and shall be based on epichlorohydrin-bisphenol A-Type epoxy resin, modified with acrylonitrile-butadiene rubber. Various additives, modifiers or fillers may be included (see 6.4 and 6.5).

3.2.3 Primer. The primer shall be a two component (Parts A and B) room temperature curing liquid epoxy and shall meet the physical properties of this specification (see 6.4).

3.3 Bond Strength (Type I and Type II). The bond strength for the Type I and Type II adhesive bonding systems shall be as specified in Table I.

TEST NO.	PROPERTY	TEST CONDITIONS	TABLE I		PARA. REF.	METRIC	
			NO. OF SPECIMENS	TEST TEMPERATURE		MIN. AVG. STRENGTH REQ'T. (MPa)	
						TYPE I	TYPE II
1	Tensile Shear	23° + 2°C and 50 ± 10% R.H.	6	23° + 2°C	4.5.5.1	11	11
2	Tensile Shear	60 minutes at 71° + 2°C	6	71° + 2°C	4.5.5.2	5.86	
3	Tensile Shear	60 minutes at -51° ± 2°C	6	-51° ± 2°C	4.5.5.3	13.8	
4	Tensile	10 days at 71° + 2°C and 95-100% R.H.	6	23° + 2°C	4.5.5.4	11	

3.4 Low temperature thermal stability (Type I and Type II). Bonded prisms shall not become detached or cracked when tested at $-62.5^{\circ} \pm 2^{\circ}\text{C}$ for 4 hours.

3.5 Mechanical shock stability (Type I only).

3.5.1 Mechanical shock stability- low temperature. Bonded prism assemblies shall not become detached during shock testing at $-43^{\circ} \pm 2^{\circ}\text{C}$. The bonded assemblies shall be shocked at 250, 300, 350 and 400 g's. The shock pulse shall have a wave form approximating a half-sine with a minimum time duration of 1.5 milliseconds.

3.5.2 Mechanical shock stability - high humidity. Bonded prism assemblies shall not become detached during shock testing after exposure to 3 temperature humidity cycles. Each cycle shall consist of exposure to 95-100% relative humidity at $70^{\circ} \pm 3^{\circ}\text{C}$ for 24 hours. The bonded assemblies shall be shocked at 250, 300, 350 and 400 g's. The shock pulse shall have a wave form approximating a half-sine with a minimum time duration of 1.5 msec.

3.6 Storage life. The Type I and Type II adhesive bonding systems shall meet the bond strength requirements of tests No. 1, 2 and 3 of Table I, if applicable, after storage for 12 months at a temperature not to exceed $30^{\circ} \pm 2^{\circ}\text{C}$ in the absence of sunlight.

3.7 Product characteristics.

3.7.1 Adhesive component.

3.7.1.1 Application life. The application life of the adhesive when mixed and ready for use at $23^{\circ} \pm 3^{\circ}\text{C}$, shall be a minimum of 30 minutes.

3.7.1.2 Curing time and temperature. When subjected to a temperature not to exceed 74°C at the bond line, the adhesive shall cure in 4 hours maximum. At a temperature of $25^{\circ} \pm 2^{\circ}\text{C}$, the cure time shall not exceed 7 days.

3.7.1.3 Curing pressure. The adhesive shall be capable of curing and making satisfactory bonded joints as described within this specification when only contact pressure is applied during the period of cure.

3.7.2 Primer component.

MIL-A-48611A

3.7.2.1 Viscosity. The viscosity of the admixed primer (i.e. primer plus curing solution) one hour after mixing shall be 15 to 20 seconds using a No. 2 Zahn cup.

3.7.2.2 Drying time. The admixed primer shall set to touch in not more than 60 minutes and shall be dried hard in not more than 24 hours.

3.7.2.3 Mixing. Equal volumes of Component A and Component B shall show easy mixing to a smooth homogeneous product.

3.7.2.4 Pot life. The admixed primer shall have a minimum useable pot life of 8 hours at 25°C.

3.8 Instruction sheet. The manufacturer shall provide a dated, coded and titled instruction sheet with each shipment of adhesive outlining instruction for its use. The instruction sheet shall include the following information:

- (a) Complete recommended pre-bonding treatments and cleaning processes.
- (b) Maximum useable storage and pot life of the adhesive and primer. The pot life of the adhesive after addition of the activator shall be based on definite quantities of the adhesive.
- (c) Mixing instruction including recommended percentage of activator and any temperature control necessary when mixing the adhesive or primer.
- (d) Application instructions, including application temperature and relative humidity, acceptable thickness range, and method of cleaning equipment.
- (e) Typical cure conditions for the adhesive and primer.
- (f) Necessary related data and precautions to be observed throughout all operations, including:
 1. SOP's in the use of the material.
 2. Physical data on the characteristics of the components (boiling point and flash point).
 3. Fire and explosion hazard data including guidance on proper protection to use if a fire occurs in the area.
 4. Reactivity data - guidance on classes of material which are not compatible with the components in the epoxy.
 5. Precautions to take in the event of a spill or leak.
- (g) Any other pertinent information relative to the use and storage of the adhesive and/or primer.

4. QUALITY ASSURANCE PROVISIONS

4.1 Responsibility for inspection. Unless otherwise specified in the contract or purchase order the supplier is responsible for the performance of all inspection



requirements as specified herein. Except as otherwise specified in the contract or order, the supplier may use his own or any other facilities suitable for the performance of the inspection requirements specified herein, unless disapproved by the Government. The Government reserves the right to perform any of the inspections set forth in the specification where such inspections are deemed necessary to assure that supplies and services conform to prescribed requirements.

4.2 Classification of inspection. The inspection and testing of the adhesive shall be classified as follows:

- (a) Qualification tests (see 4.5)
- (b) Quality conformance tests (see 4.6)

4.3 Test conditions (see 6.6)

4.3.1 Specimen conditioning. All specimens shall be conditioned at $23^{\circ} \pm 2^{\circ}\text{C}$ and 50 percent relative humidity for as least 24 hours. Other conditioning shall be prescribed in Table 1. Preparation of the test specimens shall be in accordance with 4.4 and as described herein.

4.3.2 Normal conditions (room temperature). Strength properties shall be determined for room temperature adhesive at $23^{\circ} \pm 2^{\circ}\text{C}$, no sooner than 10 minutes after specimens have reached equilibrium at such temperature.

4.3.3 Elevated temperature conditions. Conditioning of specimens for elevated temperature shear strength tests shall require a suitable oven to maintain the specimen at $71^{\circ} \pm 2^{\circ}\text{C}$ for a period of 60 minutes prior to testing.

4.3.4 Low temperature conditions. Conditioning of specimens for low temperature shear strength tests shall require a suitable conditioning chamber to maintain the specimens at $-51^{\circ} \pm 2^{\circ}\text{C}$ for a period of 60 minutes prior to testing.

4.3.5 Humidity conditions. Conditioning of specimens for humidity shear strength tests shall require a suitable conditioning chamber to maintain the specimen at $71^{\circ} \pm 2^{\circ}\text{C}$ and 95 to 100% relative humidity for a period of 10 days prior to testing.

4.4 Preparation of test specimens.

4.4.1 Preparation of shear test specimens. Test specimens as shown in Figure 1 shall be prepared in sufficient quantities for all the necessary tests. Specimens for testing all the Table 1 properties shall be prepared from 0.16 cm by 2.54 cm by 10 cm 2024-T3 aluminum conforming to QQ-A-250/4; and glass microslides 2.54 cm by 2.54 cm by 0.100 cm. The cleaning, priming, and bonding procedures shall be in accordance with the manufacturer's instruction sheet. The test specimens are to be assembled as shown in Figure 1 with the glass forming a bond of 6.45 sq. cm to one aluminum adherend 3.23 sq. cm to the other aluminum adherend.

4.4.2 Preparation of thermal and mechanical shock stability test specimens. Test specimens shall be prepared in sufficient quantities for all the necessary tests. Specimens for testing the thermal and mechanical properties shall consist of right angle optical glass prisms 4 cm x 4 cm x 4 cm bonded to an aluminum plate 6 cm x 6 cm x 1.0 cm. The priming and bonding procedures shall be in accordance with the manufacturer's instruction sheet.

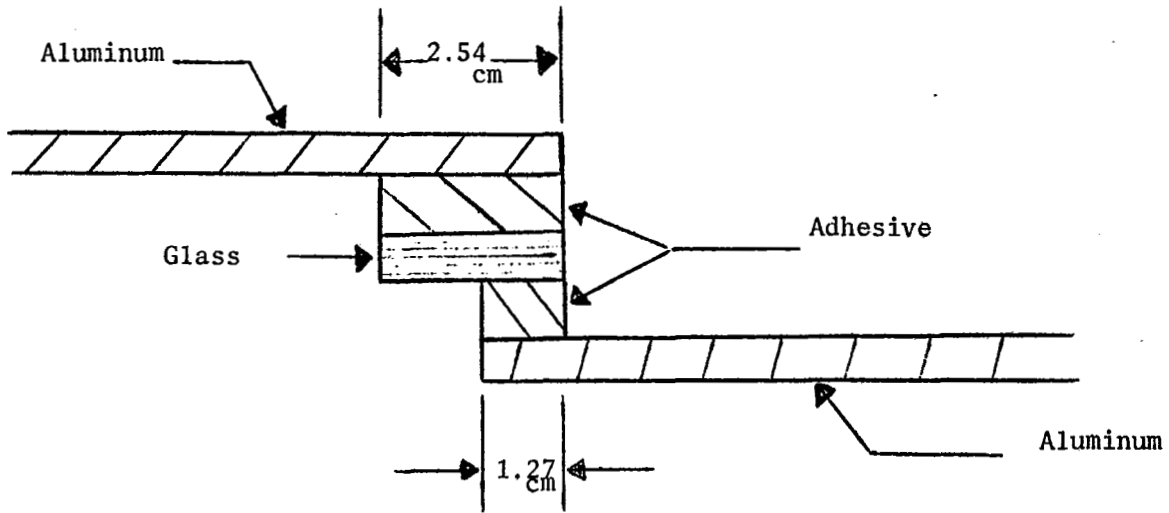

Figure 1 - Assembly of Shear Specimens

4.5 Qualification tests.

4.5.1 Qualification retest. Unless otherwise specified by the qualifying activity, adhesives which have previously passed the qualification tests but have subsequently been modified in any manner shall satisfactorily pass re-testing of the material in order to retain qualification approval. Qualification tests may be repeated on material previously found satisfactory at any time at the option of the activity responsible for qualification approval.

4.5.2 Sampling instructions. Qualification test samples of the adhesive system shall consist of .95 liter of primer (.47 liter of resin and .47 liter of curing agent to make .95 liter) and .71 liter of adhesive (.24 liter of adhesive resin and .47 liter of curing agent to make .71 liter of adhesive). Qualification test samples for the Type II adhesive system shall be as directed by the qualifying activity. The samples shall be plainly identified and forwarded to the qualifying activity.

4.5.3 Manufacturer's data. Qualification samples shall be accompanied by a test report showing results of all tests required by this specification except the tests for bond strength, low temperature thermal stability and mechanical shock stability.

4.5.4 Instruction sheet. Two copies of the manufacturer's instructions for use of the adhesive shall be furnished with the qualification samples (see 3.8).

4.5.5 Tests. The qualification tests shall consist of all the tests of the specification and shall include approval of the manufacturer's instructions.

4.5.5.1 Normal temperature tensile shear test. (Test No. 1 of Table I) The test specimen shall be gripped tightly and uniformly across the ends of the jaws of the testing machine with the jaws and specimen so aligned that the jaws are directly opposite each other, and in such a position that an imaginary straight line will pass through the center of the bonded area and through the points of suspension. All specimens shall be pulled at a jaw separation rate of 0.13 cm per minute. All failing loads shall be expressed in MPa of actual shear area, calculated to the nearest 0.65 sq cm. A total of 6 specimens shall be tested. The average strengths of these 6 specimens shall equal or exceed that specified for test number 1 in Table I. An average shear strength, less than that specified in Table I, shall cause rejection of the adhesive.

4.5.5.2 Elevated temperature tensile shear test. (Test No. 2 of Table I) The $71^{\circ} + 2^{\circ}\text{C}$ shear strength test shall be in accordance with 4.5.5.1 with the added requirement that a suitable oven shall be provided to maintain the specimens at the specified test temperature (See 4.3.3 and Table I). Six specimens shall be tested for tensile shear test listed in Table I. The average shear strength of each set of specimens tested shall equal or exceed that specified for Test No. 2 in Table I. An average shear strength less than that specified in Table I shall cause rejection of the adhesive.

4.5.5.3 Low temperature tensile shear test. (Test No. 3 of Table I) The low temperature tensile shear test shall be in accordance with 4.5.5.1 with the added requirement that a suitable chamber shall be provided in maintaining the temperature at $-51^{\circ} + 2^{\circ}\text{C}$ (see 4.3.4). Six specimens shall be tested for tensile shear strength at $-51^{\circ} + 2^{\circ}\text{C}$. The average shear strength of test specimens shall equal or exceed that specified for Test No. 3 of Table I. An average shear strength less than that specified in Table I shall cause rejection of the adhesive.

MIL-A-48611A

4.5.5.4 High humidity tensile shear test. (Test No. 4 of Table I). The humidity tensile shear test shall be in accordance with 4.5.5.1 after the specimens have been conditioned at $71^{\circ} \pm 2^{\circ}\text{C}$ and 95 to 100% relative humidity. A total of six specimens shall be tested. The average strengths shall equal or exceed that specified for Test No. 4 in Table I. An average shear strength less than that specified in Table I shall cause rejection of the adhesive.

4.5.5.5 Low temperature thermal stability. The adhesive shall be evaluated for its low temperature thermal stability by placing prism assemblies, prepared as specified in 4.4.2, in a cold box at room temperature and allowing the temperature to drop to $-62.5^{\circ} \pm 2^{\circ}\text{C}$ at a rate not to exceed 20°C per hour. The temperature shall be maintained for four hours, after which the specimens shall be returned to room temperature and examined to meet the requirements of 3.4. If one or more of the test specimens fails the test, the adhesive shall be rejected. A total of five specimens shall be tested.

4.5.5.6 Mechanical shock stability.

4.5.5.6.1 Mechanical shock stability-low temperature. The adhesive shall be evaluated for its low temperature mechanical shock stability by testing prism assemblies, prepared as specified in 4.4.2 in the vertical plane, in accordance with Procedure 1 of Method 516 specified in MIL-STD-810 except that the pulse shape, peak value and time duration shall be as specified in 3.5.1. The specimens shall be refrigerated by placing them in a cold box at room temperature and allowing the temperature to drop to $-51^{\circ} \pm 2^{\circ}\text{C}$ and maintaining that temperature for two hours. The specimens shall then be removed from the cold box and mounted on a fixture of the shock test machine and then shock tested. This must be done expeditiously so that the temperature of the assembly does not increase above -40°C . The mounted prism shall first be shock tested at 250 g's and the shock test increased at increments of 50 g's until the 400 g level has been reached. One shock test shall be made at each level. If one or more of the test specimens fails the test, the adhesive shall be rejected. A total of five specimens shall be tested.

4.5.5.6.2 Mechanical shock stability - High humidity. The adhesive shall be evaluated for its mechanical shock stability by testing prism assemblies in accordance with Procedure 1 of Method 516 specified in MIL-STD-810 except that the pulse shape, peak value and time duration shall be as in a humidity chamber at $71^{\circ} \pm 3^{\circ}\text{C}$ and 95 to 100% relative humidity for 24 hours. The specimens shall be removed from the humidity chamber and mounted on the fixture of a shock test machine and shock tested. The mounted prism shall first be shock tested at 250 g's and the shock test increased at increments of 50 g until 400 g's has been reached. Three shock tests shall be made at each interval. This combination of humidity and shock shall constitute one test cycle. A total of three cycles shall be performed. If one or more of the test specimens fails the test, the adhesive shall be rejected. A total of five specimens shall be tested.

4.5.5.7 Storage life tests. A .47 liter package of each component for Type I or Type II shall be stored under temperature and time conditions specified in 3.6. At the end of the storage period, the components shall be used in the preparation of bonded lap joint specimens as required by test nos. 1, 2, and 3 of Table I. Six specimens shall be tested at each of the applicable test conditions. The strength of the specimens shall be equal or exceed that specified for the applicable tests in Table I (see 6.3.2).

4.5.5.8 Application life. Approximately 10 grams of the mixed adhesive shall be placed in suitable container such as a plastic dish. A spatula with a 1 cm wide flat top shall be used in this test. Stir the adhesive frequently with the spatula and note the time at which the adhesive is considered to be definitely no longer spreadable on a glass or metal surface with spatula. The time to reach this consistency after mixing is the application life of the adhesive at $23^{\circ} \pm 3^{\circ}\text{C}$. The adhesive shall meet the requirements of 3.7.1.1 for application life.

4.5.5.9 Primer viscosity. The viscosity of the primer shall be determined by using a number 2 Zahn cup. The cup shall be immersed in the admixed primer one hour after mixing. The temperature of the primer shall be maintained at $25^{\circ} \pm 2^{\circ}\text{C}$. After allowing bubbles to disappear when the cup is immersed in the primer, the cup shall be removed from the liquid and simultaneously the stop watch shall be started. At the first distinct break in the stream, the stop watch shall be stopped. The average elapsed time of three such readings shall be in conformance with 3.7.2.1.

4.5.5.10 Primer drying time. The drying time shall be determined in accordance with Federal Test Method Standard No. 141, Method 4061.1 during preparation of specimens specified in 4.4 to determine compliance with 3.7.2.2.

4.5.5.11 Primer mixing. Stir part A until completely uniform. Add an equal volume of part B, stir, and examine for conformity to the requirements of 3.7.2.3.

4.5.5.12 Pot life. The admixed primer shall be brushable after 8 hours at $25^{\circ} \pm 2^{\circ}\text{C}$ to establish compliance with 3.7.2.4. The primer may be kept covered during this test to minimize evaporation of solvent.

4.6 Quality conformance tests. Quality conformance tests shall consist of the sampling tests (4.6.1) and the inspection of filled containers (4.6.2).

4.6.1 Sampling for inspection and acceptance.

4.6.1.1 Adhesive. One container of adhesive shall be selected at random from each lot. The adhesive shall be subjected to the tests in 4.5.5.8. If the sample fails any tests, the lot shall be rejected.

4.6.1.2 Primer. One container of primer shall be selected at random from each lot. The primer shall be subjected to the following determinations. If the sample fails any test, the lot shall be rejected.

(a) Drying time (4.5.5.10)

(b) Mixing (4.5.5.11)

4.6.1.3 Lot. A lot shall consist of all the material (adhesive or primer) offered for delivery at one time.

4.6.2 Sampling for inspection of filled containers. A random sample of filled containers shall be selected from each lot in accordance with MIL-STD-105 at inspection level I and AQL of 2.5 percent defective. The sample containers shall be subjected to the inspection of filled containers as specified in 4.7.

MIL-A-48611A

4.7 Inspection of filled containers. Each sample filled containers selected in accordance with 4.6.2 shall be examined for defects of construction relative to the container and the closure, for evidence of leakage and for unsatisfactory markings. Each sample filled container shall be examined to determine the amount of contents. Any container in the sample having one or more defects or under required fill shall be rejected.

5. PACKAGING

5.1 Preservation-Packaging. Preservation-packaging shall be Level A.

5.1.1 Unit protection - Type I adhesive system. The base compound and curing agent for the adhesive, and the base compound and curing agent for the primer shall each be packaged in their own containers. The ratio of the quantity contained in the base compound container for the adhesive to the quantity contained in its curing agent container shall be the same as the recommended mixing ratio of the adhesive base compound and curing agent. The ratio of the quantity contained in base compound container for the primer to the quantity contained in its curing agent container shall be the same as the recommended mixing ratio of the primer base to its curing agent. One can each of the adhesive and its curing agent along with one can each of the primer and its curing agent shall comprise one kit and these components shall be packaged together in a close fitting box.

5.1.1.1 Unit package - Type I adhesive system. The base compound for the adhesive shall be furnished in 0.24 liter multiple friction top cans and the curing agent for the adhesive shall be furnished in 0.47 liter multiple friction top cans. The base compound primer and curing agent for the primer shall be furnished in 0.47 liter containers.

5.1.2 Unit protection - Type II adhesive system. The base compound and curing agent for the adhesive shall each be packaged in their own container. The ratio of the quantity contained in the base compound container for the adhesive to the quantity contained in its curing agent container shall be the same as the recommended mixing ration. One can each of the adhesive and its curing agent shall comprise one kit and these components shall be packaged together in a close fitting box.

5.1.2.1 Unit package-Type II adhesive system. The base compound for the adhesive shall be furnished in 0.47 liter multiple friction top cans. The curing agent shall be furnished in a similar type container.

5.2 Packing. Packing shall be Level A. Unit packages shall be immobilized in a fiberboard box conforming to any compliance symbol and any style of PPP-B-636. The box shall be closed by applying pressure sensitive tape conforming to PPP-T-76 over all seams and the manufacturer's joint (see Figure 1 of PPP-T-636).

5.3 Marking. In addition to any special marking required by the contract or order, interior packages and exterior shipping containers shall be marked in accordance with MIL-STD-129. All container marking shall also include:

- (1) Manufacturer's Designation
- (2) Specification and Type
- (3) Date of Manufacture

- (4) Recommended Expiration Date
- (5) Storage Requirements
- (6) Manufacturer's Name and Address
- (7) Manufacturer's Batch Identification

5.4 Instruction sheet. A copy of the manufacturer's approved instruction sheet shall be included with each package.

6 NOTES

6.1 Intended use. The adhesive systems covered by this specification are intended primarily for use in bonding glass to metal. The materials to be bonded include glass prisms and other optical elements to their metal supports in optical fire control instruments. For maximum reliability and environmental resistance especially to humid conditions, the Type I adhesive system is recommended. Both the Types I and II adhesive systems may be used for general purpose bonding of materials such as aluminum, stainless steel, brass, bronze, plastics, glass, etc., to themselves or in dissimilar combinations. Various bond line thickness may be used for bonded assemblies, however, for the structural bonding of glass prisms to metal mounts a bond line thickness of .036 to 0.41 cm is recommended.

Mirror assemblies bonded with the adhesive systems of this specification should be thoroughly evaluated for the effect of the adhesive on the optical properties of the assemblies.

6.2 Ordering data. Procurement documents should specify the following:

- (a) Title, number and date of this specification.
- (b) Type required (see 1.2).

6.3 Qualification testing

6.3.1 Qualification. With respect to products requiring qualification, awards will be made only for such products as have, prior to the time set for opening of bids, been tested and approved for inclusion in the applicable QPL whether or not such products have actually been so listed by that data. The attention of the supplier is called to this requirement, and manufacturers are urged to arrange to have the products they propose to offer to the Federal Government, tested for qualification, in order that they may be eligible to be awarded contracts or orders for the products covered by this specification. The activity responsible for the Qualified Products List is US Army Armament Research & Development Command, ATTN: DRDAR-TST-S, Dover, NJ 07801, and information pertaining to qualification may be obtained from that activity.

6.3.2 Adhesives conforming to the other requirements of this specification may, at the option of the qualifying activity be placed on the QPL of products qualified under MIL-A-48611 prior to the completion of storage life tests. Removal of the adhesive from the Qualified Products List will be necessary, if subsequently the adhesive does not pass the storage life test.

MIL-A-48611A

6.4 Adhesive and primer composition. The formulation for an adhesive system that meets the requirements of this specification is described by a report available from US Army Armament Research & Development Command, ATTN: DRDAR-TST-S, Dover, NJ 07801

6.5 Ventilation and handling. Epoxy compounds, of the formulation referenced in 6.4 should be used in a hooded area where exhaust is available at a flow volume of $45\text{m}^3/\text{min}/\text{m}^2$ of open hood area. Personnel who might accidentally touch the epoxy should have personal protection in the form of gloves which are impervious to the epoxy components.

6.6 Bonding procedure. Recommended procedure such as surface preparation, components mixing and application, and work area environment stabilization, to be followed during the use of bonding systems conforming to MIL-A-48611, are contained in MIL-B-48612.

Custodian

Army - AR
Air Force - 99

Review Activity:

Army - MD
Air Force - 69

Preparing Activity:

Army - AR
(Project 8040-0387)

☆U.S. GOVERNMENT PRINTING OFFICE: 1981-703-023/2045